



# TECHNICAL BULLETIN –TB002

## Affecting Part Number OC15SUK12B

### Multi I/O Connection Kit - Mercruiser & Volvo Sterndrives.

Please note the following change to the recommended Torque Specification for the clamp screw on the drive collar. Original Torque figure was 45 inlbs now increased to 175 inlbs. Installation Procedure Document # IPOC15SUK12B & MDR Booklet pages 42 & 46 modified as shown below.

#### For Mercruiser Installations

##### Section C1e. – vi. Should read as follows.

- vi. Axially position Drive Collar to set the 0.25 inches gap (see graphic). Torque Clamp Screw to Drive Collar to 175 inlbs (19Nm). Torque Lock Nut to Drive Collar to 45 inlbs (5Nm).

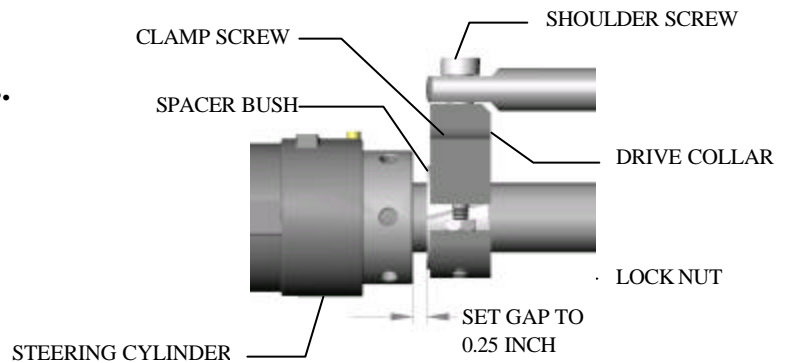

#### For Volvo Installations

##### Section C2f. – ii. Should read as follows.

- ii. Axially position Drive Collar to set the 8.25 inches dimension to Yolk (see graphic). Torque Clamp Screw to Drive Collar to 175 inlbs (19Nm). Torque Lock Nut to Drive Collar to 45 inlbs (5Nm).

